

F185A xe-dynamic

lbs/ft

F185A xe-dynamic



CRANES WITHOUT COMPROMISE

US

F185A xe-dynamic

LIFTING CAPACITY:

up to 129558 lbs.ft

MAX OUTREACH:

up to 74'0" ft with jib

OVERALL DIMENSIONS:

from: w. 8'1" ft, l. 2'1" ft, h. 7'9" ft

ELECTRONIC/HYDRAULIC EQUIPMENT:

control unit FX500

D850 digital distributor bank

RCH/RCS radio remote control unit

ADC automatic dynamic control

flow sharing

CHARACTERISTICS:

dynamic version (.2): with linkage

XP device

ProLink system with double linkage

rotation 416° with rack and pinion

FR

F185A xe-dynamic

CAPACITÉ DE LEVAGE:

jusqu'à 129558 lbs.ft

BRAS HYDRAULIQUE:

jusqu'à 74'0" ft avec jib

ENCOMBREMENT GRUE:

à partir de: w. 8'1" ft, l. 2'1" ft, h. 7'9" ft

ÉQUIPEMENT ÉLECTRONIQUE/HYDRAULIQUE:

unité de contrôle FX500

distributeur hydraulique digital D850

unité de commande radio RCH/RCS

contrôle de la dynamique ADC

flow sharing

CARACTÉRISTIQUES:

version dynamic (.2): avec bielle

dispositif XP

système ProLink avec double bielle

rotation 416° avec crémaillère et pignon

ES

F185A xe-dynamic

POTENCIA DE ELEVACIÓN:

hasta 129558 lbs.ft

MÁXIMO ALCANCE HIDRÁULICO:

hasta 74'0" ft con jib

DIMENSIONES GRÚA:

desde: w. 8'1" ft, l. 2'1" ft, h. 7'9" ft

DOTACIÓN ELECTRÓNICA/HIDRÁULICA:

unidad de control FX500

distribuidor hidráulico digital D850

unidad de mando radio RCH/RCS

dispositivo control dinámico ADC

flow sharing

CARACTERÍSTICAS:

versión dynamic (.2): con sistema de bielas

dispositivo XP

sistema ProLink y doble mecanismo a biela

rotación 416° con cremallera y piñón

Images are exclusively for product presentation - Les images sont à seule fin de la présentation du produit - Las imágenes son solo propósito de la presentación del producto



Images are exclusively for product presentation - Les images sont à seule fin de la présentation du produit - Las imágenes son solo propósito de la presentación del producto



F185A xe-dynamic
Gallery







Crane belonging to the HC1 HD5 S2 class (if installed on truck) according to EN 12999:2011 - Grue appartenant à la classe HC1 HD5 S2 (si monté sur camion) selon la norme EN 12999:2011 - Grúa que pertenece a la clase HC1 HD5 S2 (si está instalado en el camión), de acuerdo con la norma EN 12999:2011



US LINKAGE

Linkage on crane articulations, maintaining a constant lifting moment and better crane performances in terms of both dynamic lifting and static capacity.

FR BIELLETTE

Système de biellette sur articulations de la grue, permettant de maintenir un moment de levage constant et performances supérieures en termes tant de levage dynamique que de capacités statiques.

ES MECANISMO A BIELA

Mecanismo a biela de las articulaciones de la grúa, que permite obtener un momento de levantamiento constante y mayor capacidad en términos sea de levantamiento dinámico que de capacidad estática.

US

Features

BASE - Base and lower part of the column in cast steel for perfect stress distribution and greater resistance. The absence of welding ensures that the crane offers excellent characteristics of durability to fatigue.

BOOMS GUIDE - Extension booms guide shoes, with "forced" assembly to reduce vertical and horizontal clearance, ensuring greater durability. Special guide shoes material with high sliding degree and low greasing request.

TANK - Plastic tank, particularly resistant to shocks and the corrosive action of any external element.
LUBRICATION SYSTEM - Centralised lubrication system of the base to guarantee easier access for maintenance and control operations.

LUBRICATION SYSTEM - Centralised lubrication system of the base to guarantee easier access for maintenance and control operations.

OUTRIGGER - Manual extendable outriggers also in "Extra wide" execution. Available as option hydraulic extendable outriggers in standard, "Extra wide" and "Super Extra wide" execution with hoses inside the stabilizer support. Available as option manual or hydraulic tiltable outriggers.

VERSION C - Crane version with a shorter secondary arm, to allow a greater height of under-hook lifting. Offers the possibility to lift especially bulky and heavy loads vertically, near the column of the crane. Automatic hooking system for the positioning of the extension booms in transport position when crane is folded behind cab.

XP - A Fassi system that activates an excess of power in the most difficult situations, precisely when it's necessary, proportionally reducing the speed of the crane movements but, at the same time, increasing the lifting capacity.

Optional

LED WORK LIGHT - the powerful and versatile led work light with adjustable direction helps you to work safely, even in conditions of poor natural light. It can be activated by radio remote control or by the user panel.

JIB - Additional hydraulic articulation that allows you to increase the reach of the crane and, once the required height has been reached, to move the load horizontally in relation to the ground (without jeopardising the correct resting configuration of the crane). Exclusive Fassi Prolink system allowing to increase the working angle of the jib by 10 degrees above the horizontal line.

SEAT - Ergonomic, protected position to allow the operator greater control when carrying out specific movement and lifting operations. There are many possibilities of adjustments to find out the most comfortable working and control position and heated top seat as option.

SUPPLEMENTARY FUNCTIONS - Supplementary functions for the use of hydraulic accessories on the crane and the jib, protected by an exclusive Fassi system consisting of metal trays paired with highly resistant nylon guide-chains. High quality hoses resistant to the ozone action.

WINCH - Cable-operated lifting device equipped with an exclusive, patented mechanical, torque and end stop limiter system which avoids the risks resulting from direct and indirect overload applied to the winch itself. Anti-revolving cable and cable guide pulley to make easy the aligned winding of the cable on the winch drum.

FR

Caractéristiques

EMBASE - Embase et partie inférieure de la colonne en fusion d'acier pour une répartition optimum des sollicitations et pour une résistance supérieure. L'absence de soudures assure à la grue une longévité exceptionnelle.

PATINS DE GUIDAGE - Patins de guidage sur les bras d'extension, à montage "forcé" afin de réduire les jeux verticaux et latéraux prolongeant ainsi la durée de vie de l'ensemble. Patins en matériel spécial avec un degré de glissement élevé et demande réduite d'engraissage.

RÉSERVOIR - Réservoir en matière plastique très résistant aux chocs et à l'action corrosive de tout élément extérieur.

SYSTÈME DE LUBRIFICATION - Système de lubrification de l'embase centralisé pour garantir l'accès aux opérations d'entretien et de contrôle.

STABILISATEURS - Stabilisateurs à extension manuelle, disponible aussi en version "extra large". Disponibilité comme option de l'extension hydraulique pour version standard, « extra large » et « super extra large » avec les tuyauteries à l'intérieur du support stabilisateur. Disponibilité comme option des stabilisateurs pivotants manuellement ou hydrauliquement.

VERSION C - Version de la grue avec un bras secondaire plus court, de manière à obtenir une hauteur sous crochet plus importante. Elle donne la possibilité de soulever verticalement, au plus près de la colonne de la grue, des charges très encombrantes et lourdes. Système d'accrochage automatique pour le positionnement des bras d'extension en position de transport avec grue repliée derrière cabine.

XP - Système Fassi qui active un surplus de puissance dans les situations plus importantes et lourdes, au moment opportun, en réduisant de façon proportionnelle la vitesse des mouvements de la grue soumis à la dynamique (bras de levage et rotation), mais en augmentant simultanément les capacités de levage.

En option

PHARE DE TRAVAIL LED - Phare de travail led puissant et versatile à direction variable, qui permet de travailler en toute sécurité même avec une mauvaise visibilité. Peut être activé également avec les boutons de la radiocommande ou du panneau utilisateur.

JIB - Articulation hydraulique supplémentaire permettant d'augmenter l'extension de la grue et, une fois la hauteur désirée atteinte, de déplacer la charge horizontalement par rapport au sol (sans intervenir sur la configuration initiale de la grue au repos). Système Prolink Fassi exclusif augmentant l'angle de travail des rallonges hydrauliques de 10 degrés au-dessus de la ligne horizontale.

SIÈGE - Poste ergonomique et protégé qui permet à l'opérateur un contrôle optimal lors d'opérations de déplacement et de levage spécifiques. Position de travail et des commandes réglable et option siège réchauffé.

TUYAUTERIES SUPPLÉMENTAIRES - Tuyauteries supplémentaires pour l'utilisation d'accessoires hydrauliques, sur grues et sur rallonges hydrauliques, protégées par un système exclusif Fassi se composant de supports en métal couplés à des chaînes de guidage en nylon à haute résistance. Tuyauteries flexibles de grande qualité résistantes à l'ozone.

TREUIL - Dispositif de levage par câble équipé du système exclusif breveté de limiteur de couple et de fin de course mécanique, évitant les risques de toute surcharge directe ou indirecte infligée au treuil. Câble anti-giro et poulie de guidage pour enroulement aligné et facilité du câble sur le tambour.

ES

Características

BASE - Base y parte inferior de la columna de fusión de acero para una distribución ideal de los esfuerzos y para una resistencia superior. La ausencia de soldaduras confiere a la grúa excepcionales características de resistencia a la fatiga.

PATINES DE GUÍA - Patines de guía de los brazos extensibles, con montaje "forzado" para reducir las holguras verticales y laterales, garantizando una vida útil más larga. Patines especiales con elevado grado de deslizamiento y baja necesidad de engrase.

DEPÓSITO - Depósito de material plástico especialmente resistente a los golpes y a la acción corrosiva de cualquier elemento externo.

SISTEMA DE LUBRICACIÓN - Sistema de lubricación centralizada de la base para garantizar un acceso más fácil en las operaciones de mantenimiento y control.

ESTABILIZADORES - Estabilizadores a extensión manual también en versión "Extra extensible". Disponibilidad opcional de los estabilizadores a extensión hidráulica en versión estándar, "Extra extensible" y "Super Extra extensible" con tubos por el interior del soporte de los estabilizadores. Disponibilidad opcional de estabilizadores rotantes manual o hidráulico.

VERSIÓN C - Versión de grúa con un brazo secundario más corto, con el fin de permitir una mayor altura de elevación debajo del gancho. Ofrece la posibilidad de levantar en vertical, cerca de la columna de la grúa, cargas especialmente grandes y pesadas. Sistema de enganche automático para el posicionamiento de los brazos extensibles en posición de transporte con la grúa plegada detrás de la cabina.

XP - Sistema Fassi que activa una reserva de potencia en las situaciones más comprometidas y difíciles, exactamente cuando es necesario, reduciendo proporcionalmente la velocidad de los movimientos de la grúa sujetos a la dinámica (brazos de elevación y rotación), pero incrementando al mismo tiempo las capacidades de elevación.

Opcional

LUZ DEL TRABAJO LED - Luz de trabajo led potente y versátil con dirección variable, ayuda a trabajar en seguridad, también en condiciones de iluminación escasa del ambiente. Se puede activar también mediante el cuadro de pulsadores del radiocomando o del panel de usuario.

JIB - Articulación hidráulica adicional que permite aumentar el alcance de la grúa y, después de haberse alcanzado la altura deseada, desplazar la carga horizontalmente con respecto al terreno (sin perjudicar la prevista configuración en reposo de la grúa). Sistema exclusivo Prolink Fassi para aumentar el ángulo de trabajo de las prolongas hidráulicas por encima de la línea horizontal de 10 grados.

ASIENTO - Puesto ergonómico protegido para permitir al operario un mayor control en caso de operaciones específicas de manipulación y elevación. Posición de trabajo y de los mandos regulables y opción de asiento calefactado.

TUBERÍAS ADICIONALES - Tuberías adicionales para el uso de accesorios hidráulicos, en grúas y en extensiones hidráulicas, protegidas por un sistema Fassi exclusivo constituido por canaletas metálicas combinadas con cadenas de guía de nylon de alta resistencia. Tubos flexibles de alta calidad y resistentes a la acción del ozono.



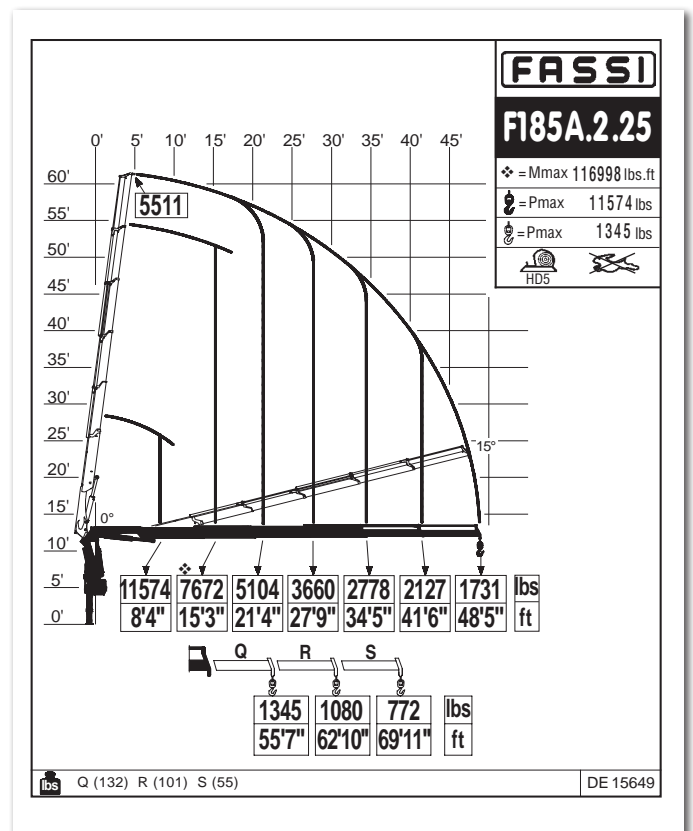
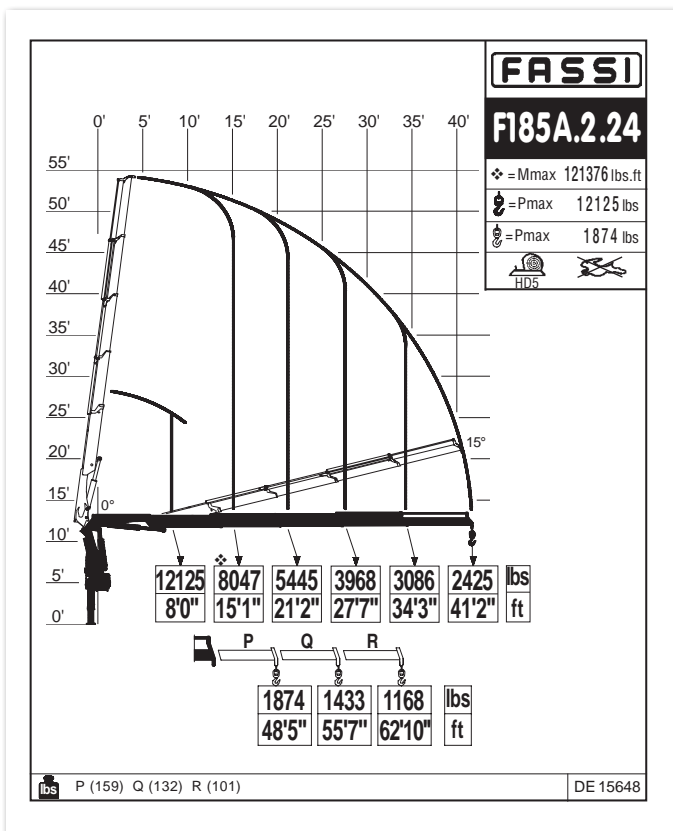
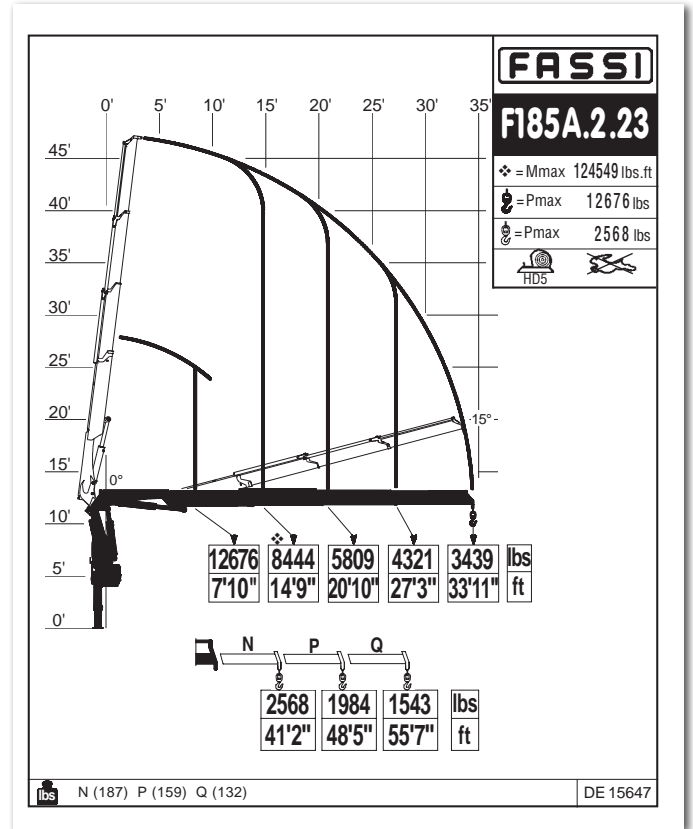
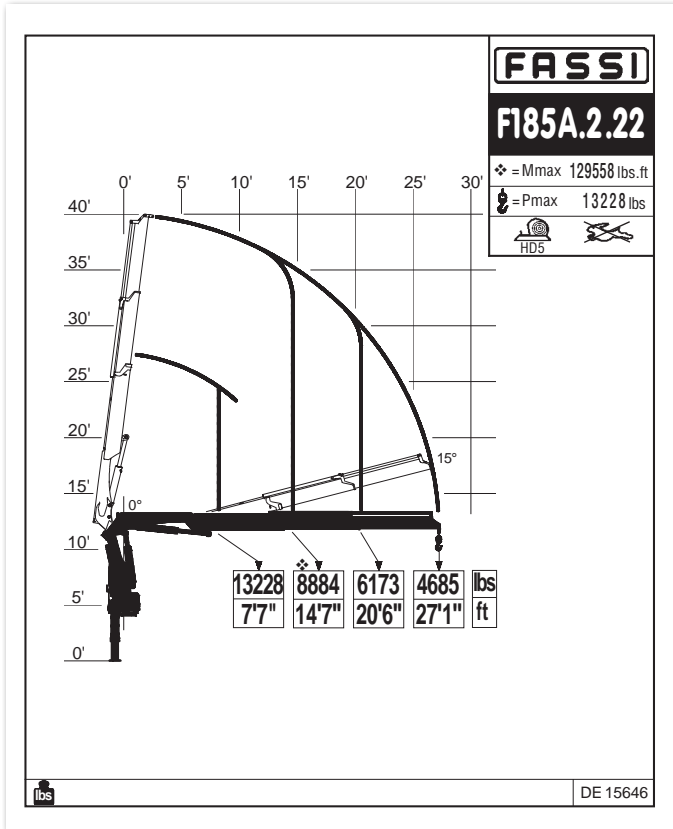

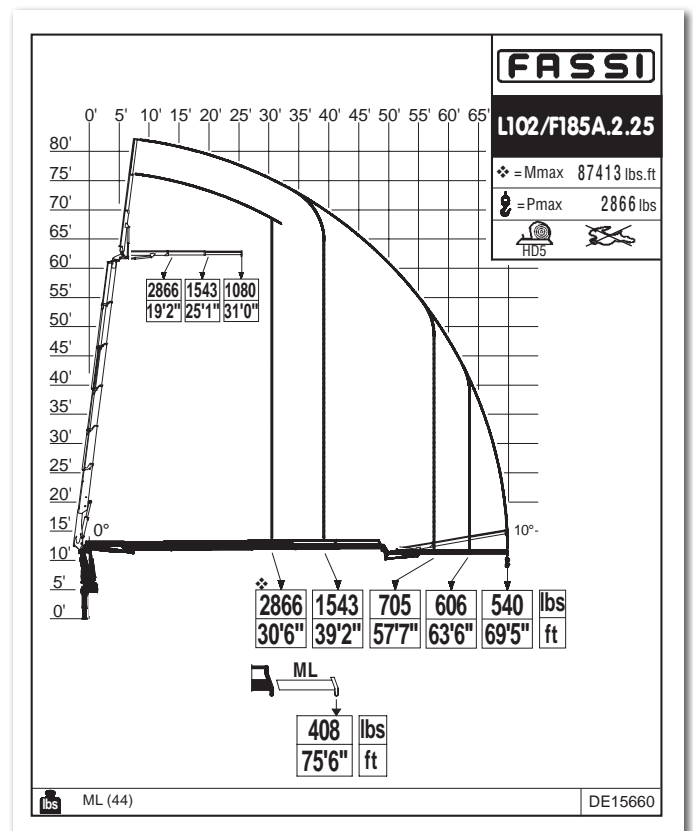
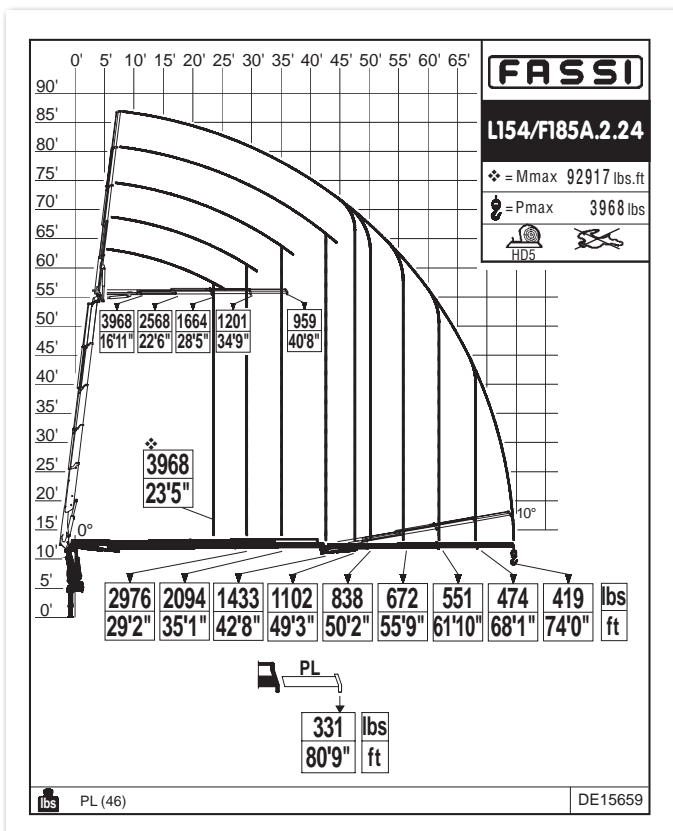
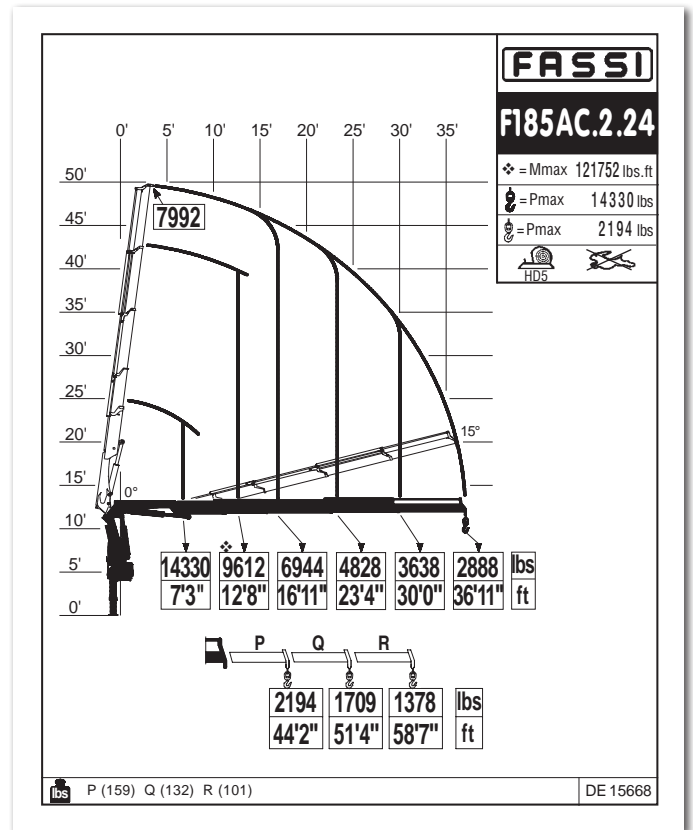
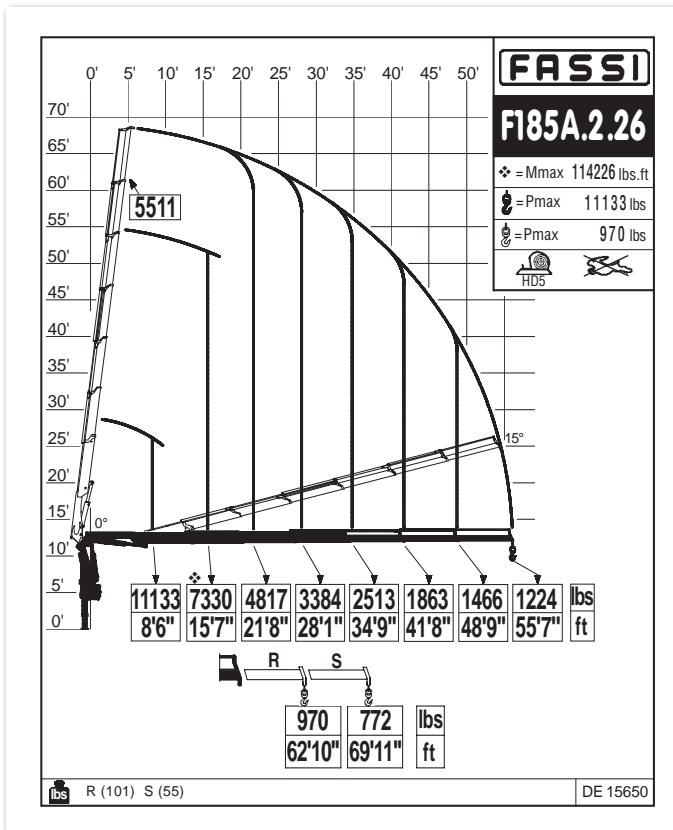







CABRESTANTE - Dispositivo de elevación por cable equipado con un exclusivo sistema patentado de doble limitador final de carrera mecánico, que evita los riesgos que derivan de las sobrecargas directas e indirectas aplicadas sobre el propio cabrestante. Cable anti giro y polea guiada para rebobinado alineado al tambor.











































F185A xe-dynamic

Technical data

lbs/ft												
	lbs.ft	ft	ft	°	lbs.ft	psi	gpm	gal	lbs	ft	ft	ft
F185A.2.22*	129558	27'0"	12'5"	416	15862	4860	10 - 16	24	4100	8'1"	2'11"	7'9"
F185A.2.23*	124549	33'11"	19'2"	416	15862	4860	10 - 16	24	4453	8'1"	3'1"	7'9"
F185A.2.24*	121376	41'2"	26'0"	416	15862	4860	10 - 16	24	4850	8'1"	3'1"	7'9"
F185A.2.25*	116998	14,75	33'1"	416	15862	4860	10 - 16	24	5160	8'1"	3'1"	7'9"
F185A.2.26*	114226	55'7"	40'0"	416	15862	4860	10 - 16	24	5423	8'1"	3'1"	7'9"
F185AC.2.23	125072	29'8"	17'4"	416	15862	4860	10 - 16	24	4340	8'0"	3'1"	7'9"
F185AC.2.24*	121752	36'11"	24'3"	416	15862	4860	10 - 16	24	4740	8'0"	3'1"	7'9"
F185AC.2.25	117412	44'1"	31'3"	416	15862	4860	10 - 16	24	5050	8'1"	3'1"	7'9"
F185AC.2.26	114218	51'4"	38'3"	416	15862	4860	10 - 16	24	5310	8'1"	3'1"	7'9"
F185A.2.23/L152	124549	54'2"	30'8"	416	15862	4860	10 - 16	24	5600	8'1"	3'7"	8'8"
F185A.2.23/L153	124549	60'9"	37'1"	416	15862	4860	10 - 16	24	5710	8'1"	3'7"	8'8"
F185A.2.23/L154	124549	66'11"	43'0"	416	15862	4860	10 - 16	24	5885	8'1"	3'7"	8'8"
F185A.2.24/L152	121376	61'3"	37'8"	416	15862	4860	10 - 16	24	5995	8'0"	3'7"	8'9"
F185A.2.24/L153	121376	67'10"	44'0"	416	15862	4860	10 - 16	24	6150	8'0"	3'7"	8'9"
F185A.2.24/L154*	121376	74'0"	50'0"	416	15862	4860	10 - 16	24	6285	8'0"	3'7"	8'9"
F185A.2.25/L102*	116998	70'2"	45'9"	416	15862	4860	10 - 16	24	5950	8'0"	3'7"	8'7"
F185AC.2.24/L152	121752	56'11"	35'11"	416	15862	4860	10 - 16	24	5885	8'1"	3'7"	8'9"
F185AC.2.24/L153	121752	63'6"	42'3"	416	15862	4860	10 - 16	24	6040	8'1"	3'7"	8'9"
F185AC.2.24/L154	121752	69'9"	48'2"	416	15862	4860	10 - 16	24	6175	8'1"	3'7"	8'9"

* US / Load diagram into the brochure - FR / Abaque de charge dans le dépliant - ES / Diagrama de carga en el catálogo

												
	Lifting capacity	Standard reach	Hydraulic extension	Rotation	Rotation torque	Working pressure	Pump capacity	Oil tank capacity	Crane weight	Crane width	Installation width	Crane height
												
	Capacité de levage	Bras standard	Extension hydraulique	Rotation	Couple de rotation	Pression d'utilisation	Débit de la pompe	Capacité du réservoir d'huile	Poids de la grue	Largeur de la grue	Largeur de montage	Hauteur de la grue
												
	Capacidad de elevación	Brazo standard	Extensión hidráulica	Ángulo de rotación	Potencia de rotación	Presión de trabajo	Capacidad de la bomba	Capacidad depósito aceite	Peso de la grúa	Anchura de la grúa	Anchura de montaje	Altura de la grúa

F185A.2 xe-dynamic

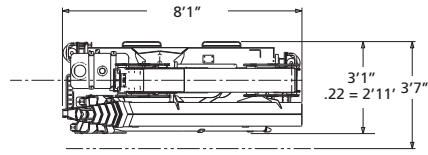
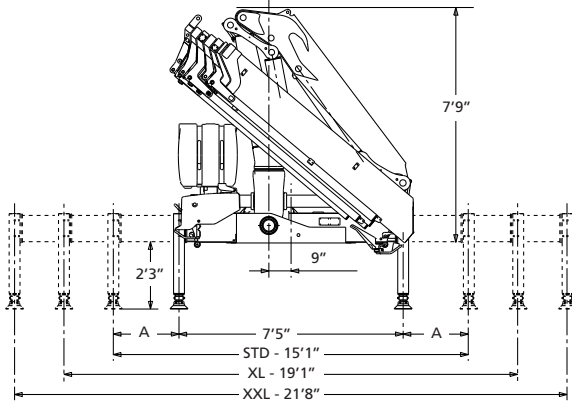

	STD	XL	XXL
A	3'10"	5'10"	7'2"

L SERIE

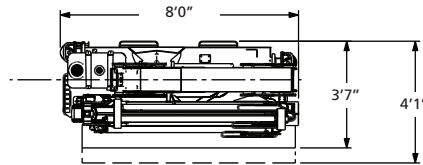
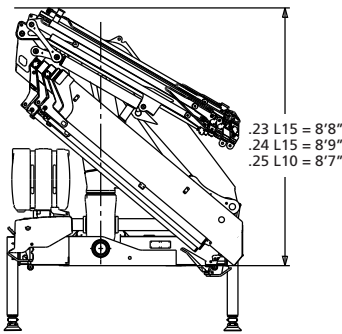

L102	705 lbs	L152	881 lbs
ML	44 lbs	ML	66 lbs
		NL	52 lbs
		PL	46 lbs

L153	1058 lbs	L154	1212 lbs
NL	52 lbs	PL	46 lbs
PL	46 lbs		

F185A.2 xe-dynamic

F185AC.2 xe-dynamic

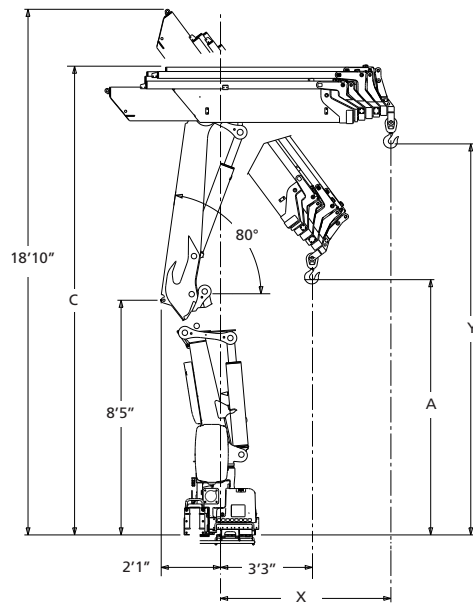
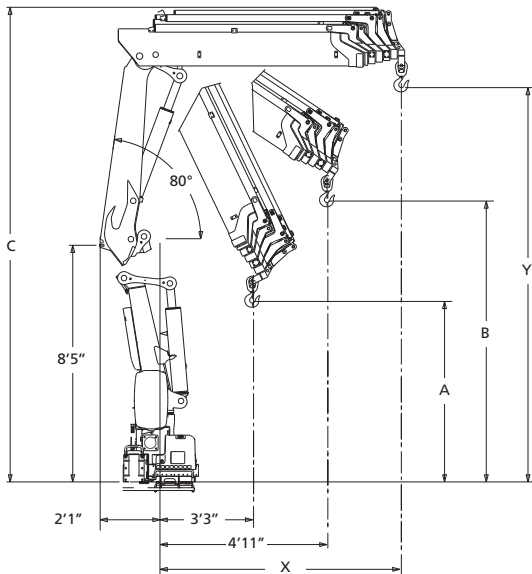

	A	B	C	X	Y
F185A.2.22	7'6"	8'7"	16'6"	7'6"	13'9"
F185A.2.23	7'2"	8'3"	16'6"	7'9"	13'10"
F185A.2.24	6'11"	7'11"	16'8"	8'1"	13'11"
F185A.2.25	6'8"	7'7"	16'8"	8'4"	13'11"
F185A.2.26	6'4"	7'3"	16'10"	8'7"	14'0"

	A	C	X	Y
F185AC.2.23	10'1"	16'6"	5'4"	13'10"
F185AC.2.24	9'9"	16'8"	5'7"	13'11"
F185AC.2.25	9'5"	16'8"	5'10"	13'11"
F185AC.2.26	9'2"	16'10"	6'1"	14'0"



US

ELECTRONIC DOCUMENTATION

All documentation related to the "Techno chips" and the crane is available in electronic format. Require all information you may need directly to your Fassi dealer or download them from the internet site: www.fassi.com.

FR

DOCUMENTATION ELECTRONIQUE

Toutes les informations relatives aux "Techno chips" et aux grues sont disponibles sous format électronique. Elles peuvent être demandées aux concessionnaires Fassi ou téléchargées sur le site www.fassi.com.

ES

DOCUMENTACION ELECTRÓNICA

Toda la información relativa a los "Techno chips" y a las grúas está disponible en formato electrónico. Se puede solicitar directamente a los concesionarios Fassi, o bien descargarse on line desde la web www.fassi.com.

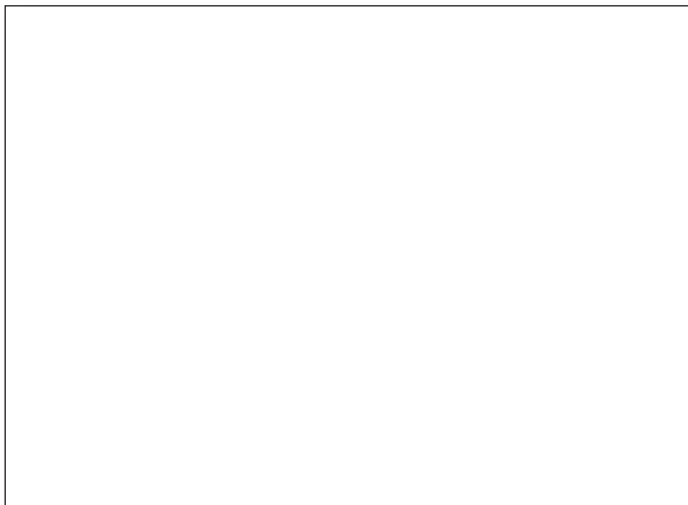

FASSI

www.fassi.com

FASSI GRU S.p.A.
Via Roma, 110
24021 Albino (Bergamo) ITALY
Tel- +39 035 776400
Fax +39 035 755020
<http://www.fassi.com>
E-mail: fassi@fassi.com

COMPANY WITH
QUALITY SYSTEM
CERTIFIED BY DNV GL
= ISO 9001 =